



CERTIFIED AUTOMATIC DOUGH ROUNDER

OPERATION'S MANUAL



The total or partial reproduction of this manual
is prohibited by any means, whether printed or electronic;
without the prior, express and written authorization of the author.

CERTIFIED AUTOMATIC DOUGH ROUNDER

OPERATION'S MANUAL

INDEX

GENERAL SAFETY INSTRUCTIONS..... 4
CAUTION..... 5
ELECTRICAL INSTALLATION..... 6
COMPONENTS..... 7
OPERATING INSTRUCTIONS..... 8
CLEANING AND MAINTENANCE..... 9

GENERAL SAFETY INSTRUCTIONS

WARNING: To reduce the risk of injury, read all instructions properly.

Failure to follow the instructions listed below can cause electric shock, fire, serious injuries, mutilation and/or damage to the equipment.

A. SAFETY IN THE WORK AREA.

- * Keep the work area clean and lit. Crowded or dark areas lead to accidents.
- * Keep children, customers, and non-company personnel away from the electrical and mechanical operation area of the equipment.
- * It is recommended to have a minimum space of one meter or three feet around the machine for safety measure and to optimize work.

B. ELECTRICAL SAFETY.

- * Machinery connections must be adapted to the power outlets.
- * Do not use adapters for the switches: since you run the risk of receiving an electric shock.
- * Do not expose the switches and/or electrical connections to rain or humidity. If water enters these elements, there is a risk that they will break down or suffer an electric shock.
- * Use cable in a single piece, if there are joints in the connections these can produce a short circuit.
- * Do not expose cables or electrical connections to heat, oil, sharp edges, or moving parts, as damaged cables can cause electric shock or short circuit.

C. PERSONAL SAFETY.

- * Do not operate the equipment if you are tired, under the influence of alcohol or drugs.
- * Wear appropriate clothing, do not wear loose clothing, or necklaces, earrings, watches, if you have long hair wear a tie to keep it up.
- * Do not climb on the structure of the machine for any reason, falls or injuries may occur.
- * Avoid using headphones, cell phones or any other equipment that works as a distraction to the operator.
- * Make correct use of personal protective equipment if any maintenance is to be carried out on the machine.
- * If any change is made to the model or component of the equipment, be it electrical or mechanical related, it must be de-energized and stop the machine completely to avoid accidents.
- * Keep limbs away from all moving parts.

CAUTION

The following symbols indicate the safety measures that must be taken before and after starting up the equipment.



ELECTRICAL RISK In which you can suffer electric shocks, if you do not comply with the electrical safety provisions.



GEAR RISK Keep your hands away from the chains and gears of the machine.

AUTOMATIC DOUGH ROUNDER

OPERATION'S MANUAL

ELECTRICAL INSTALLATION

Verify that the electrical connection is 220v. Inspect that there are no short circuits, no loose or bare wires. Ensure that all cables are isolated and without contact, check contactors and switches in good condition. It is recommended to use a 12 gauge cable for the installation.



ELECTRICAL INSTALLATION	
A	220v electrical installation
B	12 gauge cable (conduit cable)

AUTOMATIC DOUGH ROUNDER

OPERATION'S MANUAL

COMPONENTS

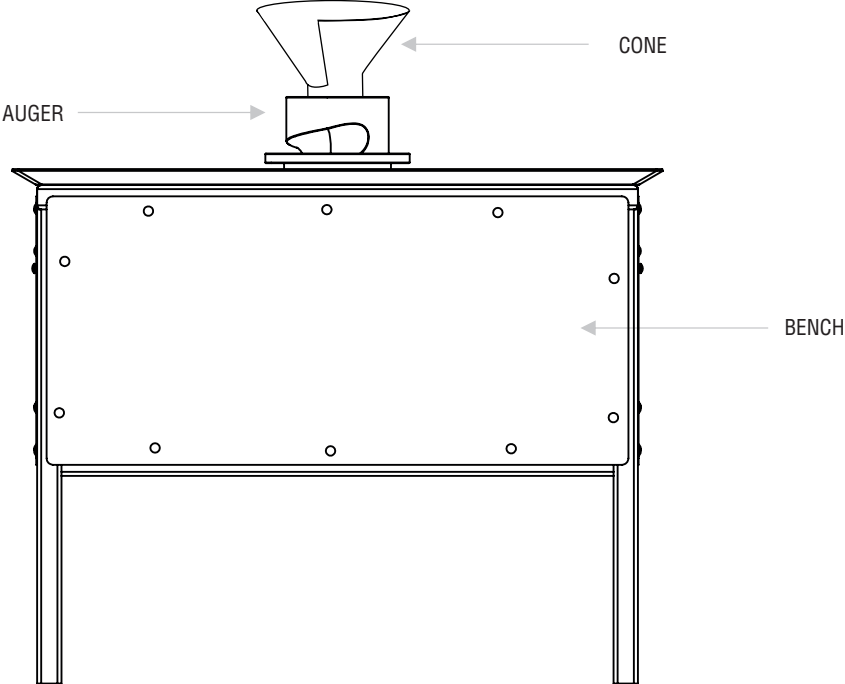

AUTOMATIC DOUGH ROUNDER

OPERATION'S MANUAL



1

Connect the equipment to a 110V power outlet.

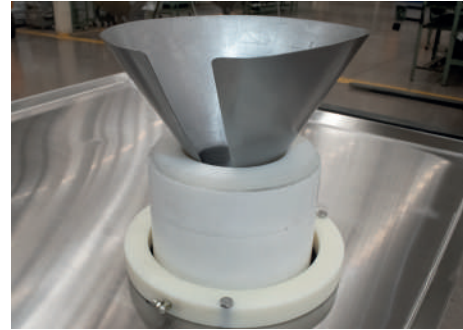

2

Verify that the cone is properly assembled on the auger.



3

Turn to release the emergency stop.



4

Turn on the equipment.

AUTOMATIC DOUGH ROUNDER

OPERATION'S MANUAL

CLEANING PROCEDURE

WARNING: Cleaning of both the auger and the tube must be performed with the machine completely stopped to prevent accidents such as crushing injuries or cuts.

1. Use warm water to remove visible dough residues (the use of a spray bottle and a cloth is recommended to facilitate removal).
2. Apply a food-grade disinfectant cleaner classified under NSF category A1, following the manufacturer's instructions.
3. Rinse with potable or distilled water to remove cleaner residues (ensure that the rinsing time is sufficient to eliminate all cleaner residues).
4. Visually verify that the surface is clean and free of residues after rinsing.
5. Allow the surface to air-dry or dry with a clean, dry cloth.

MAINTENANCE

Clean the machine before and after using it.

The duration of the spare parts will depend on the preventive maintenance and care taken to the machine. The more frequently this maintenance is done, the parts will have a longer life.

LUBRICATION

The following table shows the parts, the type of lubricant, and the frequency with which the machines and their parts must be lubricated.

PART	LUBRICANT	PERIOD
Bearings	BAT3 Grease	Every 3 days
Bands	spray cosmetic	Every 3 days

The following figures show the schematic location of the parts that require lubrication.

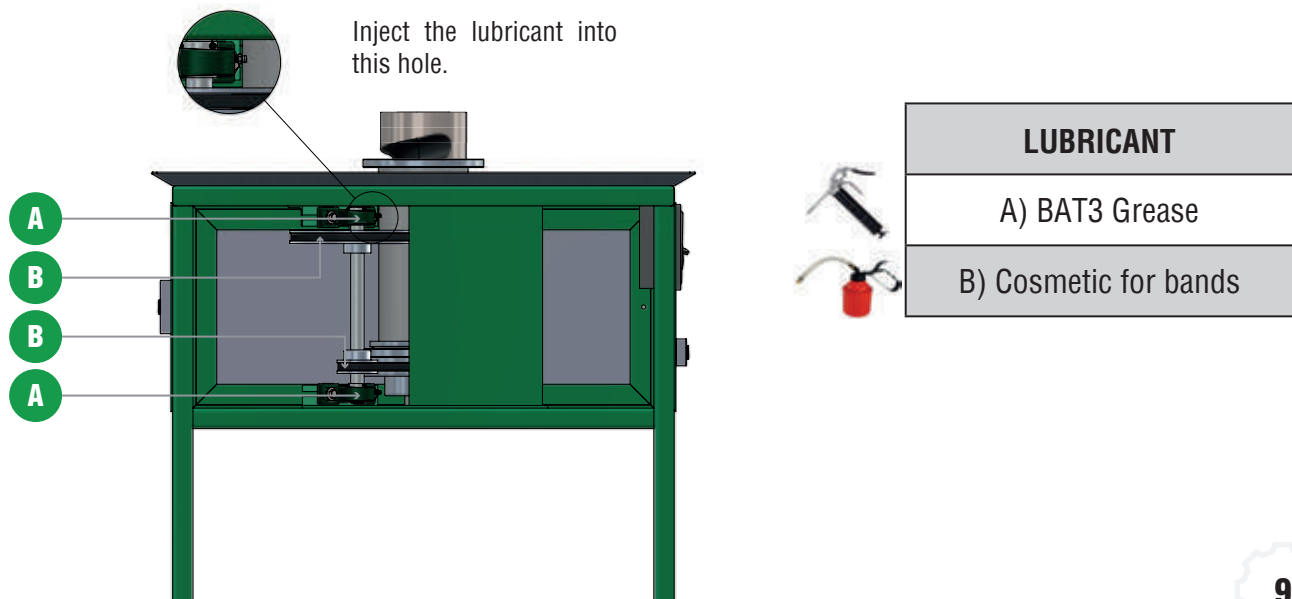



SUCURSALES | BRANCHES

SAN LUIS POTOSÍ, SLP | ABASTOS

2a Poniente No. 139
Central de Abastos
TEL: +52 444 166 01 43
lenin.abastos@manufacturaslenin.mx

SAN LUIS POTOSÍ, SLP

Av. Salvador Nava Mtz. No. 236
Col. El Paseo
TEL: +52 444 166 01 43
lenin.sanluis@manufacturaslenin.mx

CD. VALLES, SLP

Blvd. Lázaro Cárdenas. No. 499
Col. Loma Bonita
TEL: +52 481 381 78 86
lenin.valles@manufacturaslenin.mx

PLANTA | HEADQUARTERS

AV. INDUSTRIAS #3655, ZONA INDUSTRIAL CP 78395 SAN LUIS POTOSÍ, SLP. MÉXICO



444 127 11 80



+52 444 129 29 79



info@manufacturaslenin.mx

TORTILLADORASLENIN.COM
MEXICANTORTILLAMACHINE.COM