



CE

# MLR-180 TORTILLA MACHINE

OPERATION'S MANUAL



The total or partial reproduction of this manual  
is prohibited by any means, whether printed or electronic;  
without the prior, express and written authorization of the author.



# **MLR-180 TORTILLA MACHINE**

OPERATION'S MANUAL

---

## INDEX

GENERAL SAFETY INSTRUCTIONS.....	4
OPTIMAL OPERATION CONDITIONS.....	5
SUPPLY CONDITIONS.....	5
CAUTION.....	6
MLR-180 MACHINE DIMENSIONS .....	7
TECHNICAL LABEL .....	8
SEMI-AUTOMATIC START.....	9
ELECTRICAL COMPONENTS.....	10
ELECTRICAL DIAGRAMS.....	12
GAS AND ELECTRICAL INSTALLATION .....	16
OPERATING INSTRUCTIONS.....	17
CLEANING PROCEDURE.....	22
MAINTENANCE.....	23
LUBRICATION .....	24

## GENERAL SAFETY INSTRUCTIONS

**WARNING:** To reduce the risk of injury, read all instructions properly. Failure to follow the instructions listed below can cause electric shock, fire, serious injuries, mutilation and/or damage to the equipment.

### A. SAFETY IN THE WORK AREA.

- \* Keep the work area clean and lit. Crowded or dark areas lead to accidents.
- \* Do not operate the equipment without first checking all gas connections with soapy water, to ensure that there are no leaks that could cause an explosion.
- \* Keep children, customers and non-company personnel away from the electrical and mechanical operation area of the equipment.
- \* It is recommended to have a minimum space of one meter or three feet around the machine for safety measure and to optimize work.

### B. ELECTRICAL SAFETY.

- \* Machinery connections must be adapted to the power outlets.
- \* Do not use adapters for the switches: since you run the risk of receiving an electric shock.
- \* Do not expose the switches and / or electrical connections to rain or humidity. If water enters these elements, there is a risk that they will break down or suffer an electric shock.
- \* Use cable in a single piece. If there are joints in the connections these can produce a short circuit.
- \* Do not expose cables or electrical connections to heat, oil, sharp edges, or moving parts, as damaged cables can cause electric shock or short circuit.
- \* When the gas sensors detect a leak, the machine will stop completely.

### C. PERSONAL SAFETY

- \* Do not operate the equipment if you are tired, under the influence of alcohol or drugs.
- \* Wear appropriate clothing, do not wear loose clothing, or necklaces, earrings, watches, if you have long hair wear a tie to keep it up.
- \* Do not climb on the structure of the machine for any reason, falls or injuries may occur.
- \* Avoid using headphones, cell phones or any other equipment that works as a distraction to the operator.
- \* Make correct use of personal protective equipment if any maintenance is to be carried out on the machine.
- \* If any change is made to the model or component of the equipment, be it electrical, mechanical or gas related, it must be de-energized, cut off the gas supply and stop the machine completely to avoid accidents.
- \* Keep limbs away from all moving parts.

*The requirements according to ISO 13849-1 standards have been applied to the command functions.*

## OPTIMAL OPERATION CONDITIONS

\*The machine is designed to work adequately in an environment with a relative humidity of less than 50% at a maximum temperature of 40°C.

\*It is recommended that the equipment be operated in low humidity environments so that both its electrical and mechanical components have a longer useful life. Exposure to salty and/or high humidity environments leads to a higher degree of corrosion in these components.

\*The machine is capable of operating at any altitude. However, it is important to keep in mind that at a height close to sea level, a gas pressure greater than that indicated will be necessary to perform optimal work (gas pressure: 500g. calculated at 1874 meters above sea level).

\*The control panel has an IP56 protection rating, which helps protect the components against the entry of solid objects, dust, accidental contact and water. However, its installation and storage must be free of such contaminants to safeguard the overall quality of the equipment.

\*In the event of any movement of machinery, it is recommended to use a forklift, and that said fastening be done on the side of the oven if the equipment is assembled. If this is not the case, the head must be secured in such a way that the electrical panel and gear guard are positioned on the sides of the vehicle to avoid any possible damage.

\*If the machine is not installed immediately, it must be stored in a dry place, in a normal position, at a constant temperature and free of dust, gases, rust, corrosive smoke and/or other conditions that affect it.

\*Optimal storage conditions are: relative air humidity of up to 60%, with ambient temperature greater than 5°C and less than 40°C

\*For design reasons, condensation effects are not foreseen in the nominal working conditions. It is recommended to install an extractor hood to expel vapors generated by the oven.

## SUPPLY CONDITIONS

The machine is capable of operating correctly under the specified supply conditions:

-Permanent voltage: 207-253 VAC.

-Frequency: 49-51Hz.

-Harmonic distortion: < 12%

-Voltage imbalance <2%

-Voltage interruption: <3 ms.

-Voltage gap: <20%

*\*Max. loop impedance in a TT distribution system it should not be greater than 1.9 Ohms.*

## CAUTION

The following symbols indicate the safety measures that must be taken before and after starting up the equipment.



**HOT HAZARD** Some parts of the machine are hot while in operation.



**TAKE CARE OF YOUR HANDS** Hands should not be inserted while the machine is working.



**ELECTRICAL RISK** In which you can suffer electric shocks if you do not comply with the electrical safety provisions.



**GEAR RISK** Keep your hands away from the chains and gears of the machine.



**DO NOT COVER THE BARREL'S AIR INTAKE.** Keep your hands away from the air inlet of the barrel.



**HOT SURFACE** Oven lids are hot while in operation and for some time afterwards until they reach room temperature.

# MLR-180 TORTILLA MACHINE OPERATION'S MANUAL

## MLR-120 MACHINE DIMENSIONS

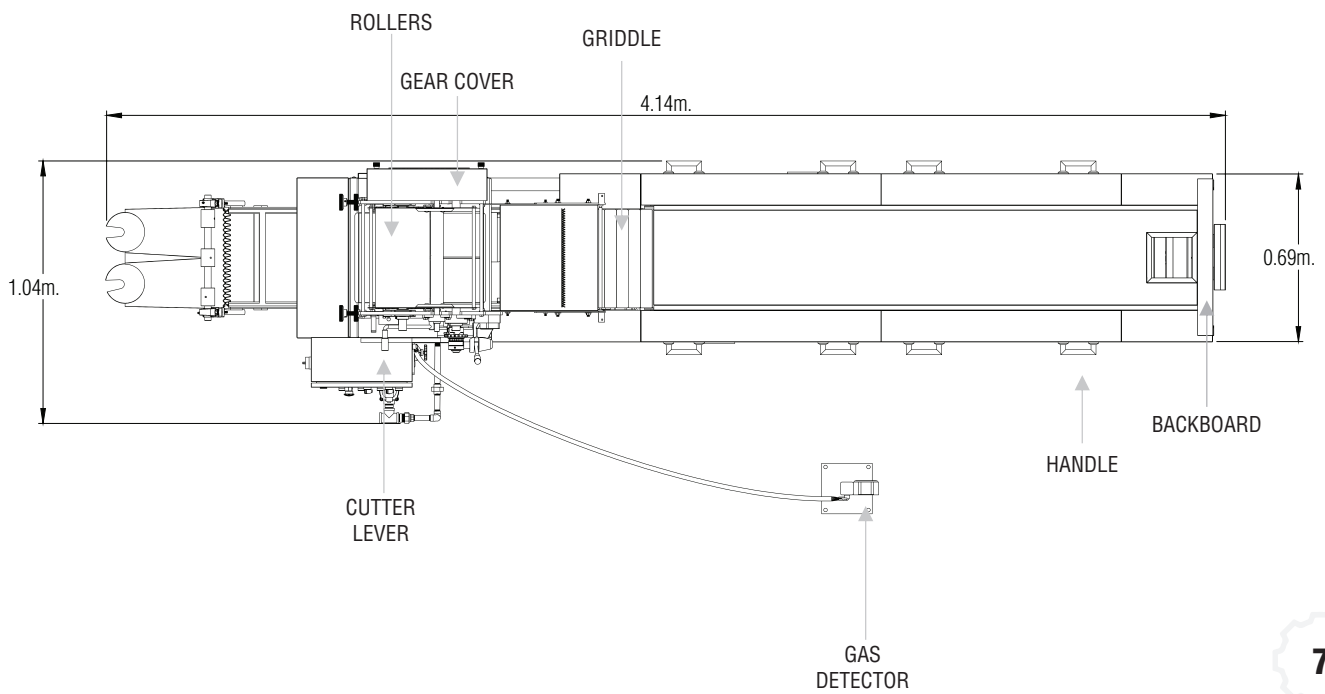
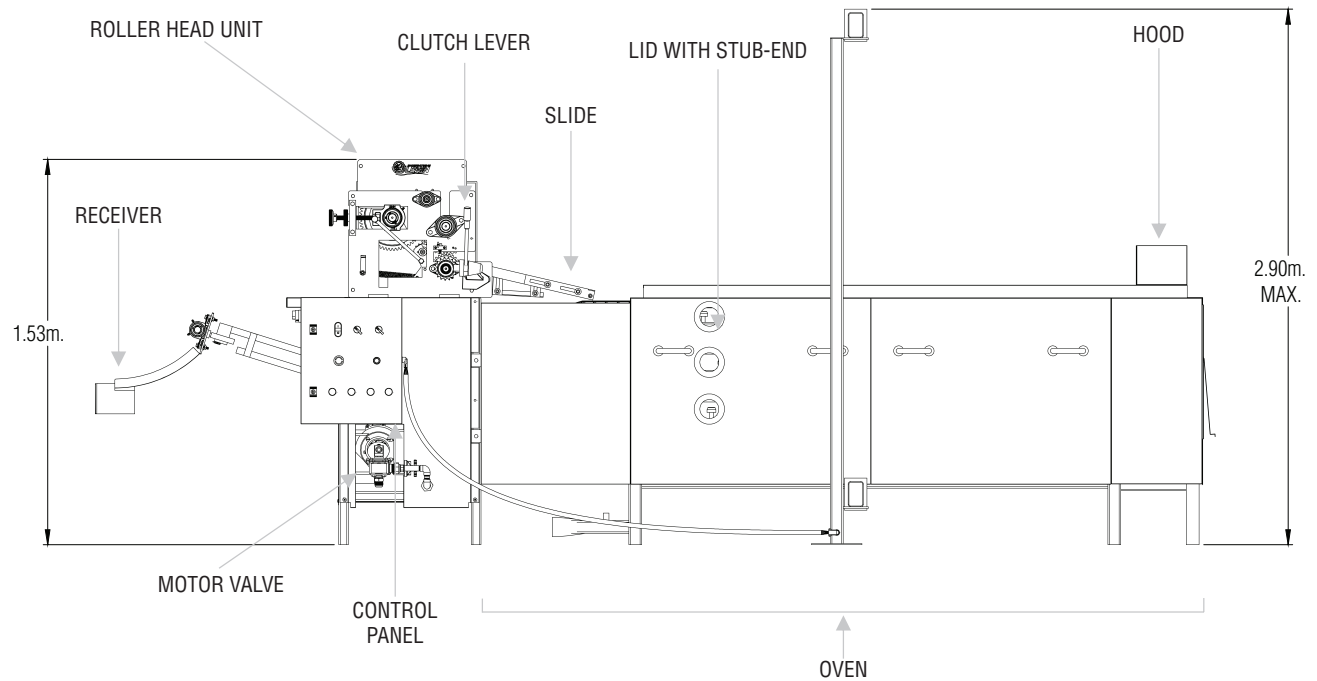

# MLR-180 TORTILLA MACHINE OPERATION'S MANUAL

## TECHNICAL LABEL

<b>MLR180</b>	BIFÁSICA / TWO PHASE TRIFÁSICA / THREE PHASE	
Alimentación eléctrica / Power Supply	230VCA - 50Hz	
Motores / Motors	2HP / ½HP	
Consumo eléctrico / Electrical consumption	2,4 kW/h	
Corriente nominal / Rated current	16A	
ICC / SCC	80A	
Presión min. de gas LP / Min. LP gas pressure	14 PSI=lb/pulg <sup>2</sup>	
Poder calorífico / Calorific value	291,350 BTU/h	
Consumo máximo de gas / Maximum gas consumption		
Gas natural / Natural gas	8.2 m <sup>3</sup> /h	
Gas LP (vaporizado) / LP gas (vaporized)	3.1 m <sup>3</sup> /h	
MLR180CE-020224-00		
HECHO EN MEXICO POR EQUIPOS E INSUMOS PARA LA INDUSTRIA ALIMENTICIA S.A. DE C.V. MADE IN MEXICO BY		



## SEMI-AUTOMATIC START

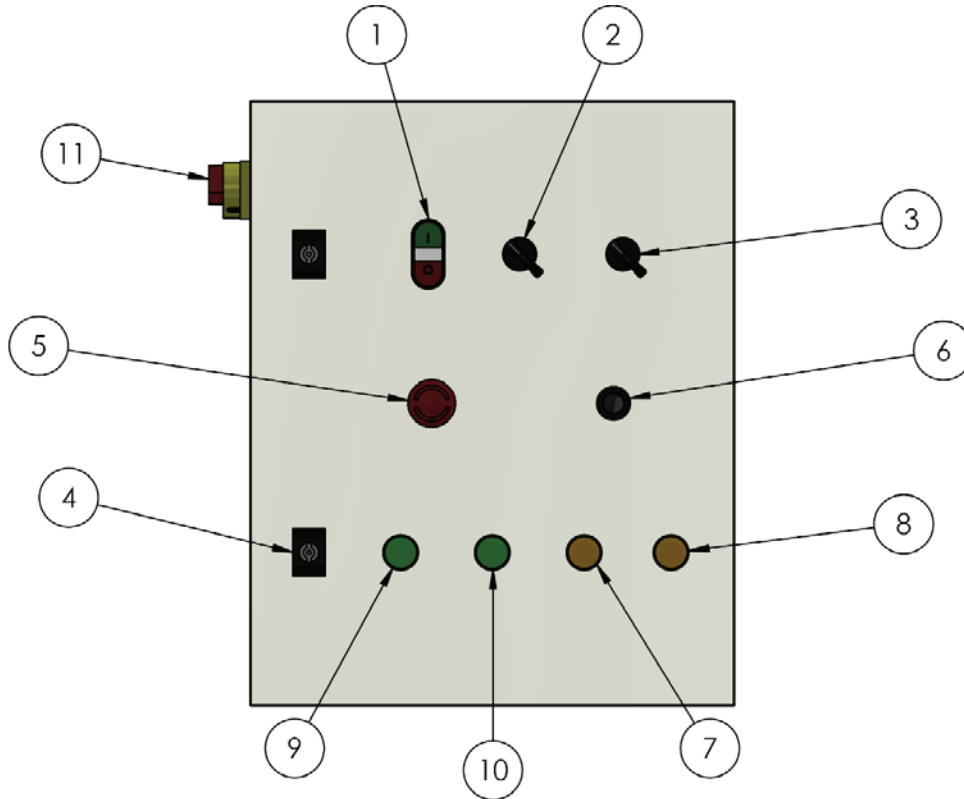

No.	DESCRIPTION	FUNCTION
1	START AND STOP BUTTON. NA-NC ZB4BW84C	TURN ON OR OFF THE MACHINE TRANSMISSION MOTOR AND MOTOR VALVE
2	2 POSITION SELECTOR ZB4BJ2C	TURN ON OR OFF MAIN BURNERS VALVE
3		TURN THE PILOT BURNER VALVE ON OR OFF
4	CONTROL PANEL LOCK	
5	ROTATING EMERGENCY STOP BUTTON XB4BS542	STOPS THE MACHINE
6	BLACK FLUSH BUTTON HEAD ZB4BA5C	ACTIVATE THE SPARK PLUGS TO LIGHT THE BURNERS
7	PILOT LIGHT A16 LED AMBER	TRANSMISSION MOTOR FAILURE INDICATOR
8		CARBURETOR VALVE MOTOR FAILURE INDICATOR
9	COLOR PILOT LIGHT A16 LED GREEN	TRANSMISSION MOTOR IN OPERATION INDICATOR
10		BURNER VALVE IN OPERATION INDICATOR
11	DISCONNECTING SWITCH CAT. VCF01	ENERGIZE OR DE-ENERGIZE THE MACHINE

# MLR-180 TORTILLA MACHINE OPERATION'S MANUAL

## ELECTRICAL COMPONENTS

DESCRIPTION	MANUFACTURER/TRADE BRAND	TYPE/MODEL	TECHNICAL DATA	INTERNATIONAL STANDARD	ACCORDANCE
PILOT LIGHT A16 GREEN LED	WEG MÉXICO, S.A. DE C.V.	A16-22DS	220 VCA - 20 MA	IEC/EN 60947 5-1	CE
PILOT LIGHT A16 AMBER LED	WEG MÉXICO, S.A. DE C.V.	A-1622DS	220 VCA - 20 MA	IEC/EN 60947 5-1	CE
ILLUMINATED START AND STOP BUTTON NO-NC	WEG MÉXICO, S.A. DE C.V.	ZB4-BW84C	AC 15 - 240 VCA 3 AMPERS	IEC/EN 60947 5-1	CE
HEAD FOR DOUBLE KEY ILLUMINATED BUTTON	WEG MÉXICO, S.A. DE C.V.	ZB4-BW065	AC 15 - 240 VCA 3 AMPERS	IEC/EN 60947 5-1	CE
2 POSITION SELECTOR	WEG MÉXICO, S.A. DE C.V.	ZB4-BJ2C	AC 15 240 VCA 3 AMPERS	IEC/EN 60947 5-1	CE
BASE FOR SELECTOR NO	WEG MÉXICO, S.A. DE C.V.	ZB4-BZ101C	AC 15 240 VCA 3 AMPERS	IEC/EN 60947 5-1	CE
BLACK FLUSH PUSH BUTTON	WEG MÉXICO, S.A. DE C.V.	ZB4-BA5C	AC 15 240 VCA 3 AMPERS	IEC/EN 60947 5-1	CE
BASE FOR FLUSH BUTTON NO	WEG MÉXICO, S.A. DE C.V.	ZB4-BZ101C	AC 15 240 VCA 3 AMPERS	IEC/EN 60947 5-1	CE
ROTATING EMERGENCY STOP BUTTON	WEG MÉXICO, S.A. DE C.V.	XB4-BS542	AC 15 240 VCA 3 AMPERS	IEC/EN 60947 5-1	CE
NC AUXILIARY BLOCK	WEG MÉXICO, S.A. DE C.V.	ZBE-102	AC 15 240 VCA 3 AMPERS	IEC/EN 60947 5-1	CE
CONNECTION CHART	WEG MÉXICO, S.A. DE C.V.	SERIE "H" -60	60 AMPERS 400 VCA	IEC/EN 60947 5-1	CE
CONTACTOR CWB-18-11-30D23	WEG MÉXICO, S.A. DE C.V.	CWB-18-11-30D23	18 AMPERS 220 VCA 50-60 HZ	IEC 60947-1	CE
RELAY RW27-2D3-U015	WEG MÉXICO, S.A. DE C.V.	RW27-2D3-U015	10-15 AMPERS 690 VCA	IEC EN 60947-1	CE
CONTACTOR CW07 10E	WEG MÉXICO, S.A. DE C.V.	CW07 10E	7 AMPERS 220 VCA 50-60 HZ	IEC 60947-1	CE
RELAY RW17-1D3-U004	WEG MÉXICO, S.A. DE C.V.	RW17-1D3-U004	2.8-4.0 AMPERS 690 VCA	IEC EN 60947-1	CE
SOLENOID VALVE 1/2" 220 VAC 50-60 Hz PARKER	PARKER HANFIN CORPORATION, FLUID CONTROL DIVISION	7221GBN4VN00N0C11103	220 VCA 50-60 HZ	IEC60204-1(2016)	CE
8 PIN ENCAPSULATED RELAY	RELPOL	R15-2012-23-5230-WT	10 AMPERS 240 VCA/28 VCD	EN 61810-1	CE
RELAY BASE FOR 8 10AMPERS 300 VAC	ZJW	10F-2Z-C3 2115	10 AMPERS 300 VCA	EN 61810-1	CE
IP56 CABINET 500 X 400 X 200 MM S	SCHNEIDER ELECTRIC, S.A.	NSYCRN54200-M	IP56 500 X 400 X 200 MM	IEC 62208	CE
MAG CIRCUIT BREAKER CAT. GV2ME10 3F SCHNEIDER	SCHNEIDER ELECTRIC, S.A.	GV2ME10	220 VCA 4.0-6.3 AMPERS	EN/IEC 60947-4-1	CE
MAG CIRCUIT BREAKER CAT. GV2ME16 3F SCHNEIDER	SCHNEIDER ELECTRIC, S.A.	GV2ME16	220 VCA 9.0-14.0 AMPERS	EN/IEC 60947-4-1	CE

# MLR-180 TORTILLA MACHINE OPERATION'S MANUAL

DESCRIPTION	MANUFACTURER/TRADE BRAND	TYPE/MODEL	TECHNICAL DATA	INTERNATIONAL STANDARD	ACCORDANCE
VARIO CAT DISCONNECTING SWITCH. VCF01	SCHNEIDER ELECTRIC, S.A	VCF01	3F 20 AMPERS 600 VCA	IEC 60529	CE
INDUSTRIAL FUSE 4 AMPS 500 V gG 10 X 38 MM	SCHNEIDER ELECTRIC, S.A	13304	4 AMPERS 500 VCA GG	IEC 60529	CE
INDUSTRIAL FUSE 2 AMPS 500 V G 10X38 MM	SCHNEIDER ELECTRIC, S.A	13302	2 AMPERS 500 VCA GG	IEC 60529	CE
SINGLE POLE FUSE HOLDER SELECTOR 32 AMPERS	SCHNEIDER ELECTRIC, S.A	DF101	32 AMPERS 440 VCA	EN/IEC 60269-2	CE
BIPOLAR ENERGY DISTRIBUTOR 100 AMPERS 0776225	ARNO CANALI	BD10072	100 AMPERS	EN60998-1	CE
MIRO GROUP CURRENT TRANSFORMER	REELEN	JBK3-300	250 VCA - 50- 60 HZ	850431920	CE
1/2 HP MOTOR SINGLE PHASE	LESSON	C6C28FB26G	220 VCA 50 HZ IP54	IEC-34-5	CE
2 HP ENGINE SINGLE PHASE 4 POLES 182	LESSON	C182C14FB6C	220 VCA 50 HZ IP44	IEC34-1	CE
GAS LEAK DETECTOR MODEL B2	BITWO ELECTRONICS	B2	85-260VCA 50-60HZ	NOM-003-SCFI-2014	NOM
THERMOMAGNETIC SWITCH	WEG MÉXICO, S.A. DE C.V.	MDW-B20-3	20 AMPERS 400 VCA 50-60HZ	EN/IEC 60947-1	CE

## ELECTRICAL DIAGRAMS

### MAIN POWER DIAGRAM

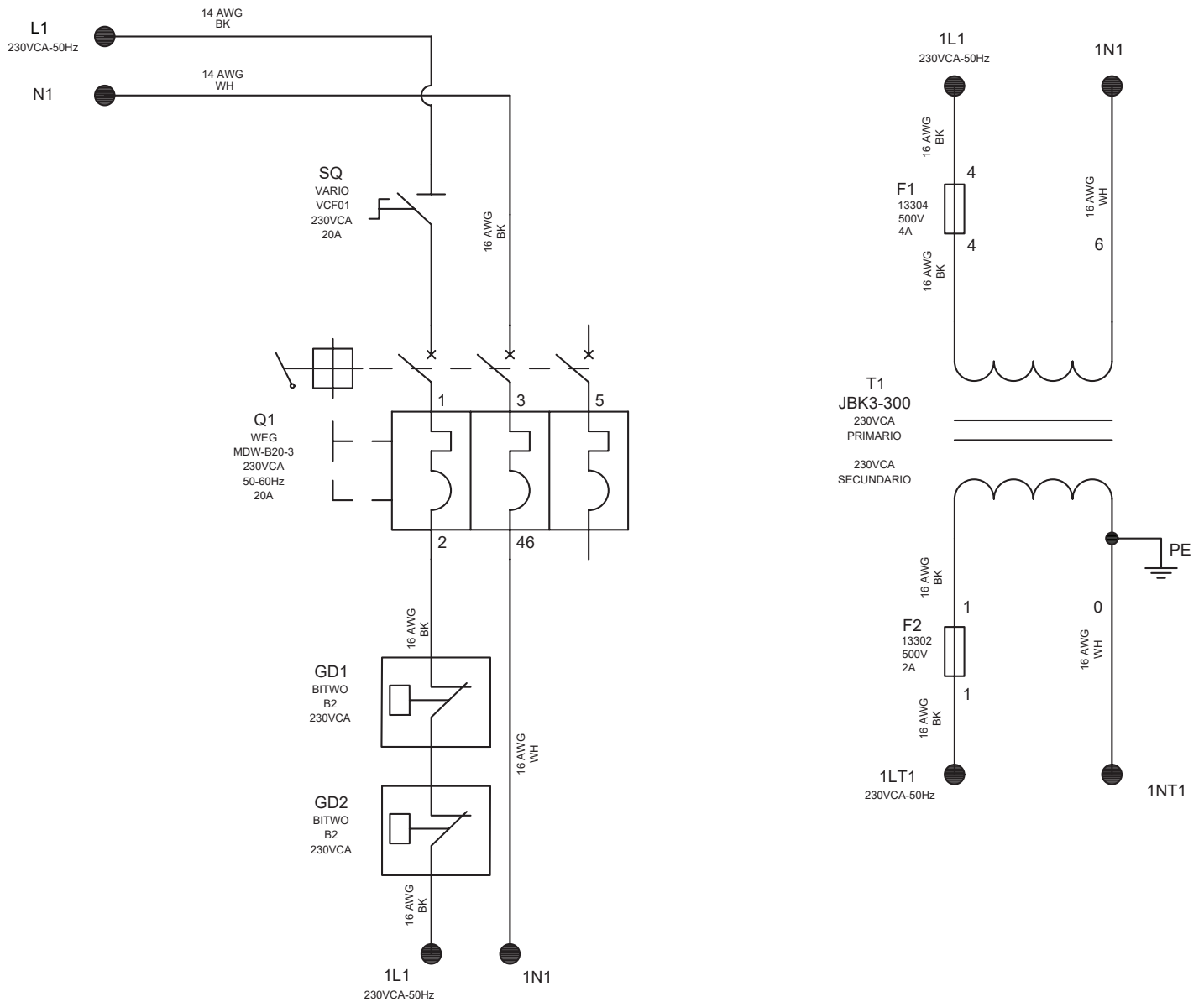

# MLR-180 TORTILLA MACHINE OPERATION'S MANUAL

## SEMI-AUTOMATIC ELECTRICAL IGNITION CONTROL DIAGRAM

TRANSMISSION MOTOR	TRANSMISSION MOTOR FAILURE INDICATOR	CARBURETOR VALVE MOTOR	CARBURETOR VALVE ENGINE FAILURE INDICATOR	MAIN BURNERS ELECTRO VALVE	BURNER VALVE INDICATOR IN OPERATION	PILOT BURNER ELECTRO VALVE
--------------------	--------------------------------------	------------------------	---	----------------------------	-------------------------------------	----------------------------

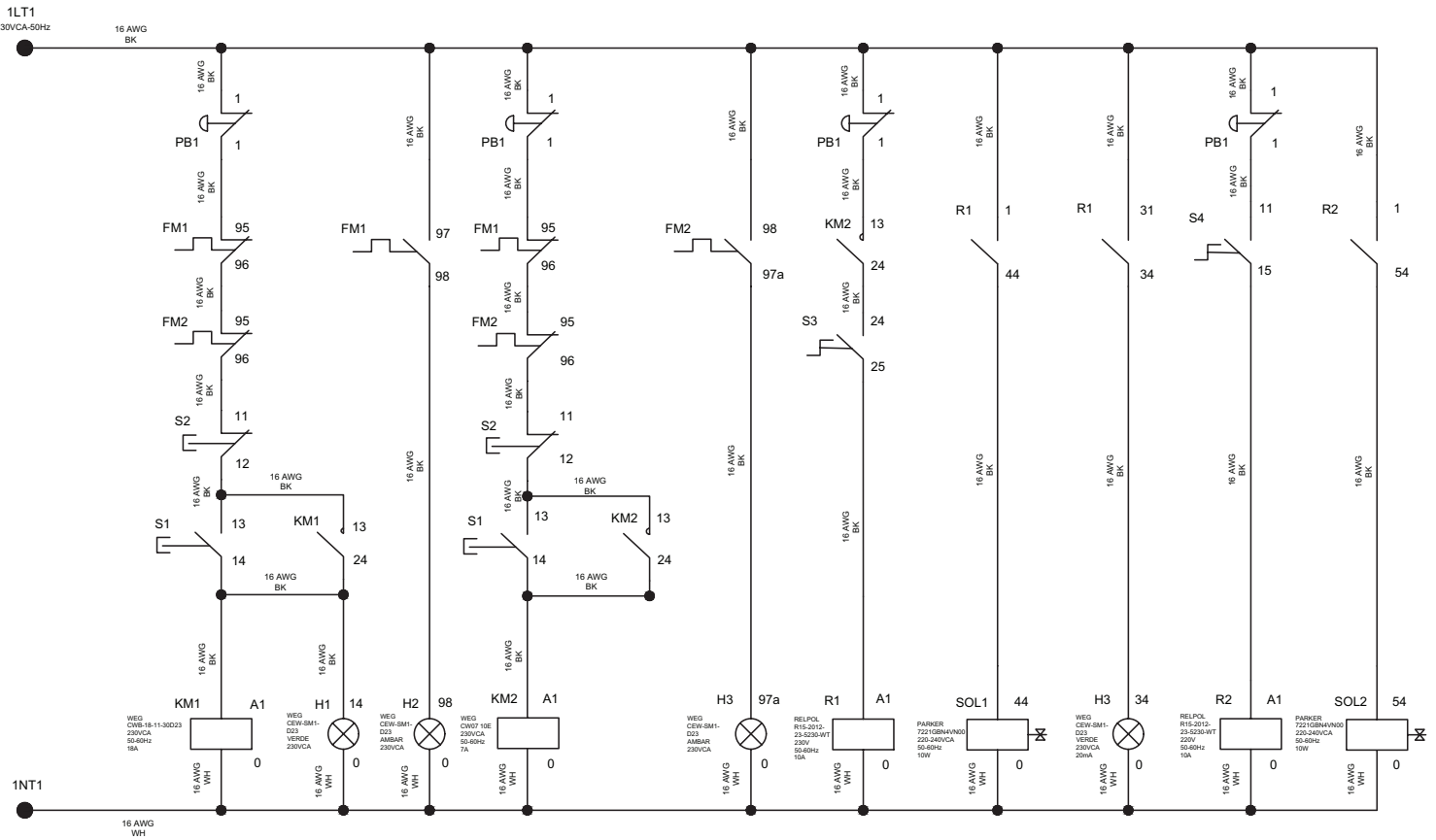

# MLR-180 TORTILLA MACHINE OPERATION'S MANUAL

## POWER DIAGRAM SEMI-AUTOMATIC ELECTRICAL IGNITION

TRANSMISSION MOTOR

CARBURETOR VALVE MOTOR

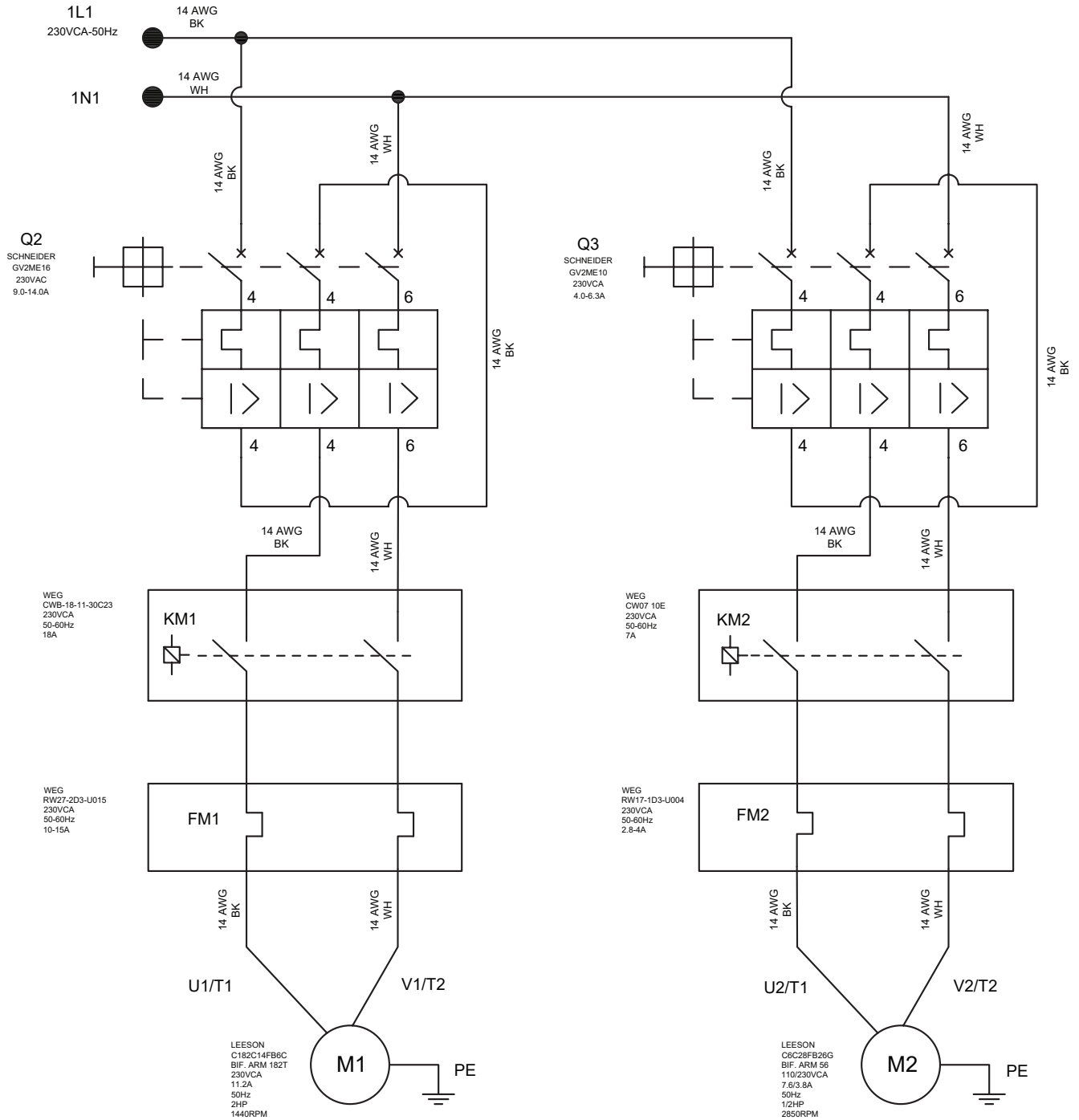

## IGNITION DIAGRAM SEMI-AUTOMATIC ELECTRICAL IGNITION

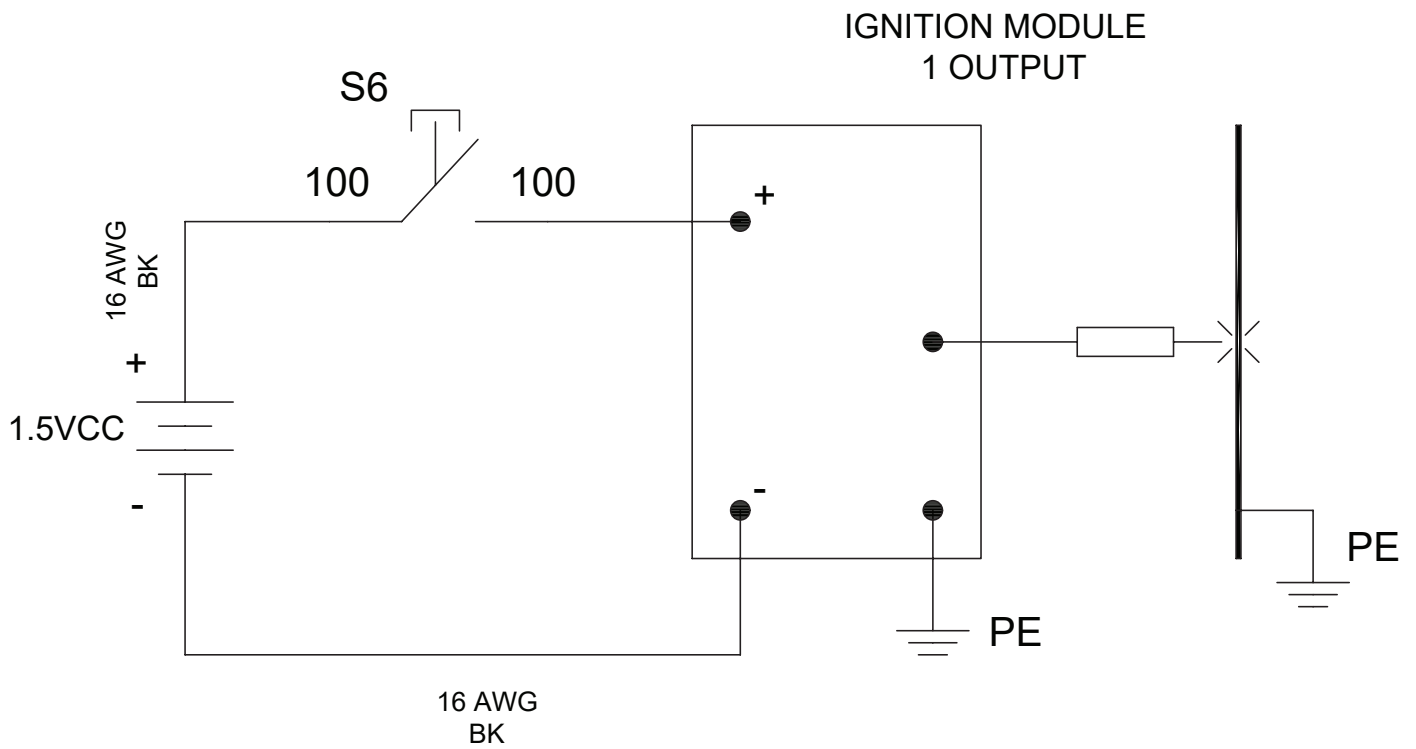

# MLR-180 TORTILLA MACHINE OPERATION'S MANUAL

## GAS AND ELECTRICAL INSTALLATION

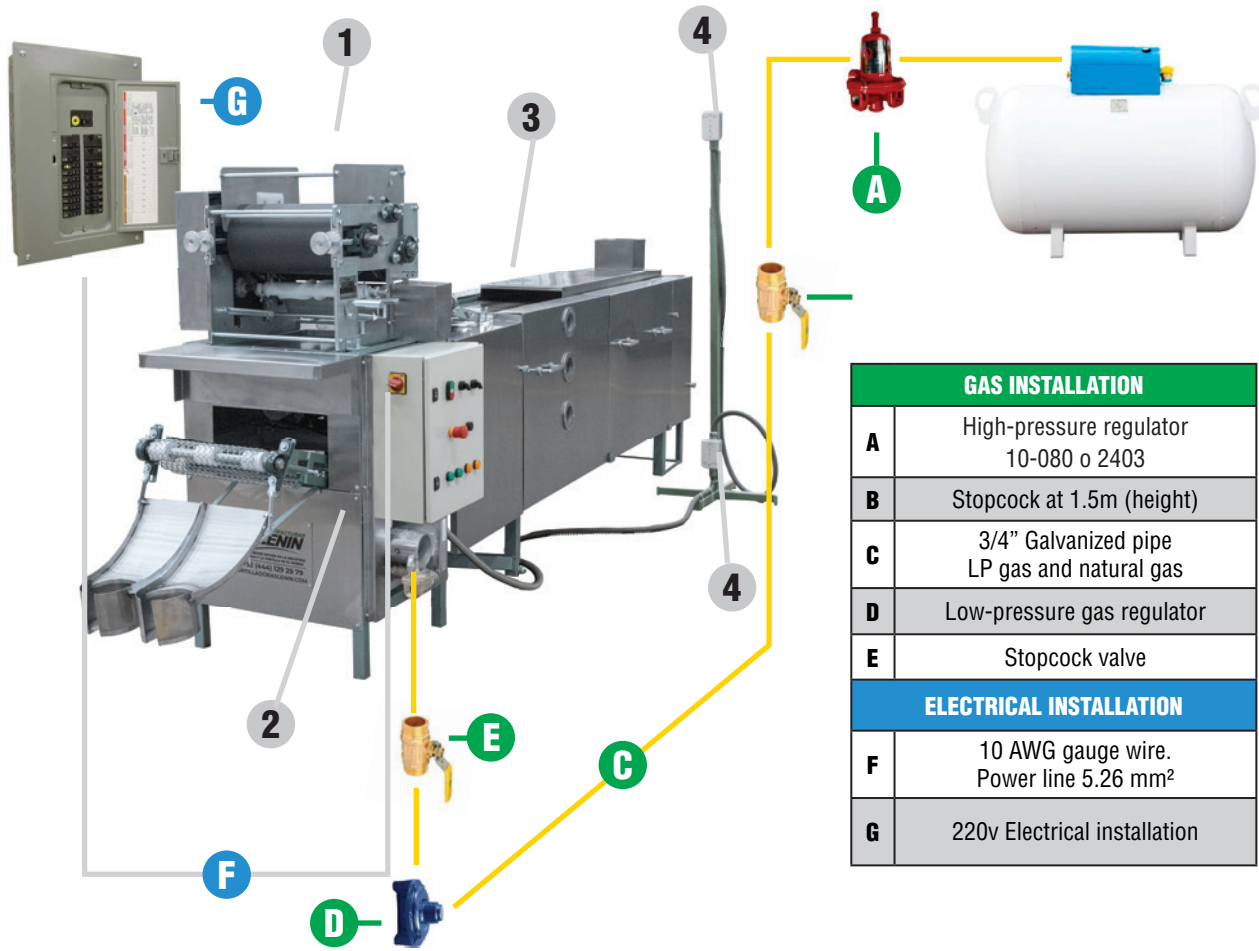

- 1 Rollers head      2 Transmission bench      3 Oven      4 Gas leak detector

\*Use 10 gauge cable for maximum power conductor section.

\*Maximum power line impedance value with protected installation with 20A type c thermomagnetic switch is 1.1 Ω (Zs).

\*Set the base of the gas detectors at a distance of between 50 and 70 cm from the oven.

\*It is recommended to adjust the height of the upper detector pedestal approximately 30cm from the ceiling.

\***Note:** If you want to install the gas detectors on the wall, they must be placed at a distance of 4m from each other and at a height of 30cm from the ceiling in the case of natural gas and 20cm from the floor in the case of LP gas.

\***Location classification:**

\***Zone 2:** Under normal operating conditions, the formation of explosive atmospheres is not likely or, if formed, only remains for a short period of time.



# MLR-180 TORTILLA MACHINE OPERATION'S MANUAL

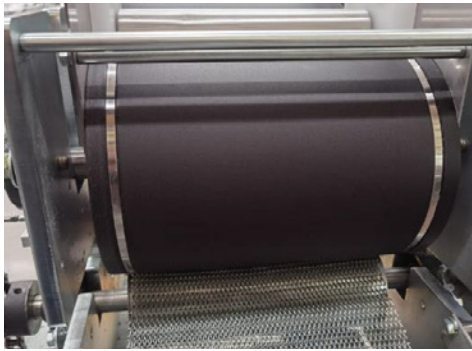

**1**

Check that the straps rotate freely.



**2**

Check wire tension



**3**

Place cutter on the base, verify that it is correctly installed and secured.



**4**

Spray grooves and straps with water to remove excess dough.



**5**

Connect gas intake to carburetor valve.



**6**

Open the gas outlet stopcock.

# MLR-180 TORTILLA MACHINE OPERATION'S MANUAL



**A** Activate main switch



**B** Unlock emergency stop



**C** Press green button (ON) motor ignition



**D** Main motors will start and the indicator will illuminate (green light)

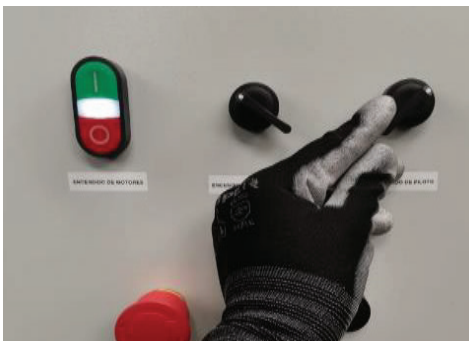

**E** Turn pilot ignition knob (ON).



**F** Press ignition spark button

# MLR-180 TORTILLA MACHINE OPERATION'S MANUAL

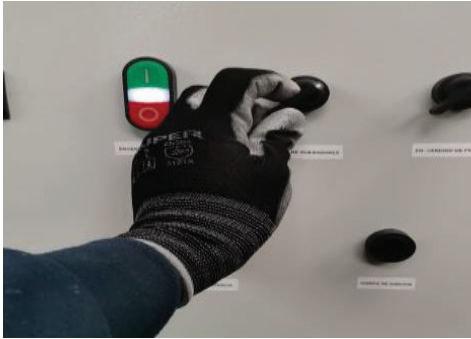

**G**

Once the pilot burners are lit, turn the main burner ignition knob (ON).

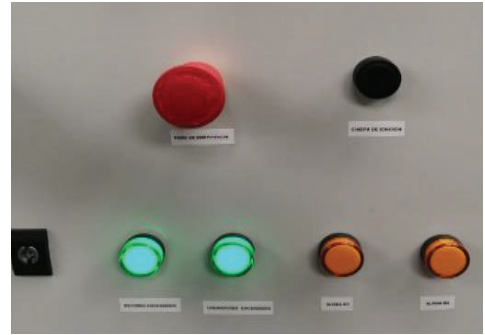

**H**

Burners will light and the burners indicator will turn on (green light)  
Interlock emergency stop.



**I**

Turn the pilot ignition knob (OFF).



**7**

Turn lower carburetor valve knob to regulate flame intensity.



**8**

Check flame intensity on nozzles, wait 3 minutes for the griddle to heat up.



**9**

Raise clutch lever.

# MLR-180 TORTILLA MACHINE OPERATION'S MANUAL



10

Add dough to rollers.

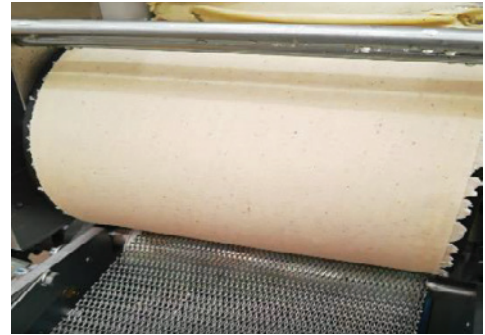

11

Adhere curtain of dough to the front roller.



12

Release cutter lever.



13

Verify that the dough unsticks correctly.



14

Check the tortilla on the griddle.



15

Adjust tortilla thickness by turning the adjustment knobs:  
Clockwise thins the tortilla;  
counterclockwise makes the tortilla thick.

# MLR-180 TORTILLA MACHINE OPERATION'S MANUAL

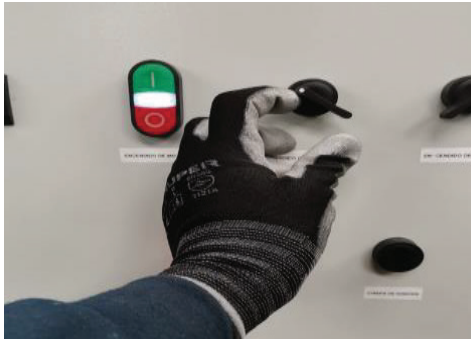

J

At the end of tortilla production, turn the burner ignition knob (Off).



K

Press the red motor ignition button (OFF).



L

Lock emergency stop



F

De-energize main switch



G

If there is a transmission motor failure, the left amber indicator will illuminate.



H

If there is a failure in the valve motor, the right amber indicator will illuminate

**Important note:** To avoid the accumulation of gas inside the machine, the main burner valve will NOT be activated if the motors are not running.

## **CLEANING PROCEDURE**

**WARNING:** Cleaning both the rollers and the base must be done with the machine completely stopped to avoid accidents such as crushing.

### **FRONT ROLLER CLEANING**

1. Remove the dough residues from the front roller at total stop with your hands.
2. Turn the machine on again to change the position of the roller, turn off the machine and proceed with cleaning. You must carry out this action as many times as necessary to complete the cleaning of the roller.
3. Clean the cable tie grooves with a plastic bristle brush to prevent the build-up of mass that may break the wire when it dries.
4. Wipe the remaining dough from the top of the roller with a damp cloth.
5. After removing the dough residues from the roller, there will be an excess.
6. Spread a little water after removing the remaining dough to complete the cleaning of the roller.
7. Clean the rollers with a dry cloth after spreading water over them to remove excess moisture.

### **CLEANING THE REAR ROLLER**

8. Clean the rear roller, pour in a little water, and wipe with a cloth to remove any dough residues.  
**NOTICE:** You will need to turn the machine on to change the position of the roller as many times as necessary to clean them completely.
9. After you have cleaned the roller from the front and back, you should wipe the upper part of the stainless steel roller with a damp cloth.
10. Use a damp cloth to clean the base of the bench and remove lumps from the slide with a wire brush.

## MAINTENANCE

Clean the machine before and after using it.

The duration of the spare parts will depend on the preventive maintenance and care taken to the machine.

The more frequently this maintenance is done, the parts will have a longer life.

Before carrying out any type of intervention on the machine, whether for cleaning, maintenance or replacement of any component, the main switch must be deactivated and a safety padlock ( $\varnothing 4-8\text{mm}$ ) must be placed as shown in the following section to avoid any accident:



**A**

Main switch in OFF position.



**B**

Press the main switch lock.



**C**

Without stopping pressing,  
place padlock in slot



**D**

Ensure that the padlock is closed.

## LUBRICATION

The following table shows the parts, the type of lubricant, and the frequency with which the machines and their parts must be lubricated.

<b>PART</b>	<b>LUBRICANT</b>	<b>PERIOD</b>
Chains	BAT 3 Grease	3 times per week
Reducer	SAE 80/90 Mineral Oil	Every 3 months
Packed bearings	BAT 3 Grease	Every 3 days
Griddle hinges	Graphite	Every week
Gears	BAT 3 Grease	Every week
Clutch sprocket	BAT 3 Grease	3 times per week
Slide bronze bushing	BAT 3 Grease	3 times per week



# MLR-180 TORTILLA MACHINE OPERATION'S MANUAL

The following figures show the schematic location of the parts that require lubrication.

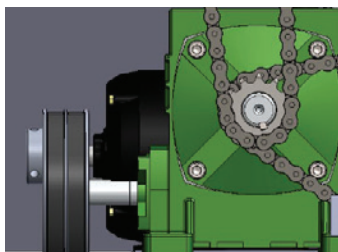
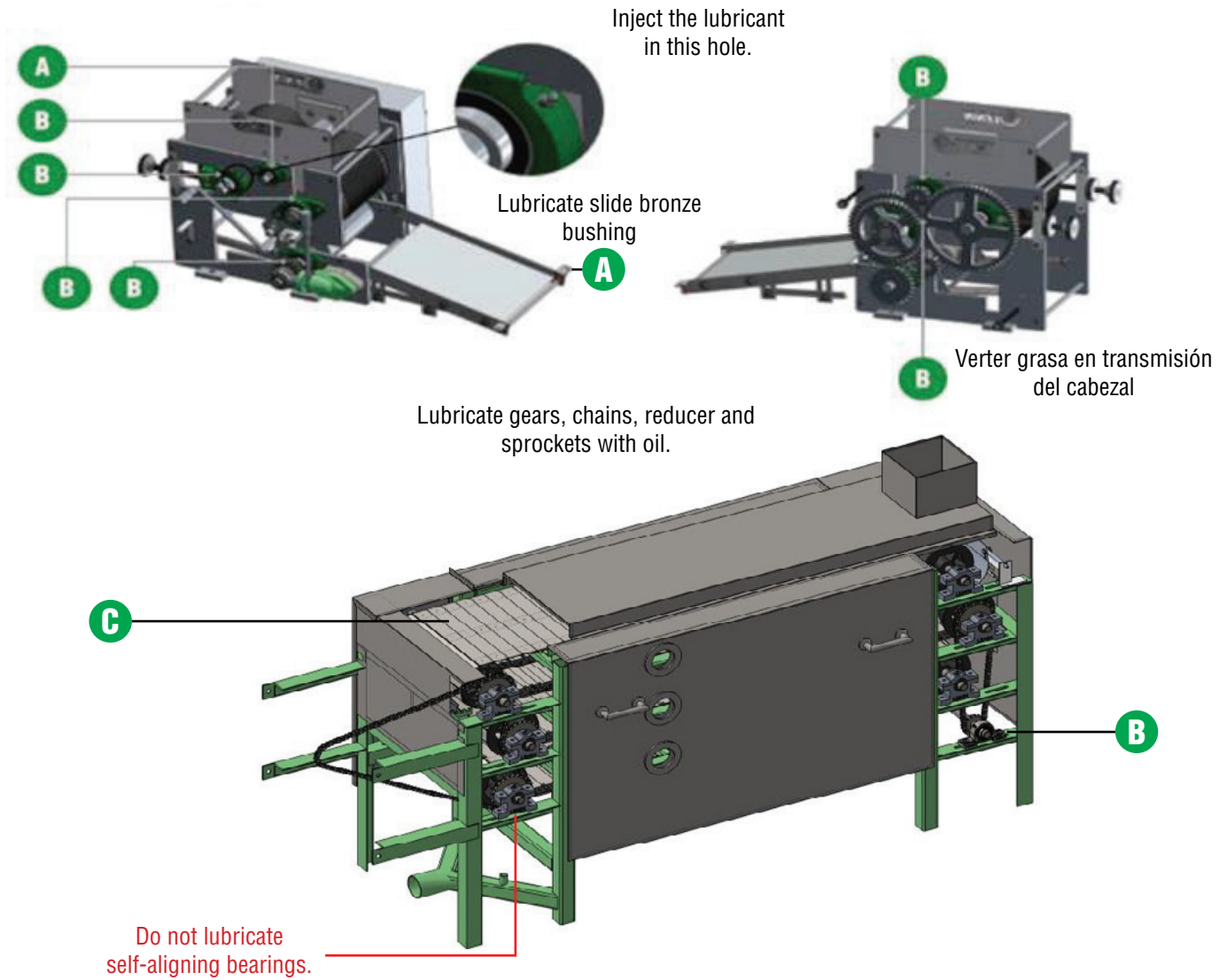

It is recommended to change the oil every three months. The used oil must be drained and 400 ml of new SAE 80/90 mineral oil must be added.

The following table shows the type of lubricant to put in all parts of the machine.

LUBRICANT
A) SAE 80/90 mineral oil
B) BAT 3 Grase
C) Graphite



## **HEADQUARTERS**

AV. INDUSTRIAS #3665, ZONA INDUSTRIAL  
CP 78395 SAN LUIS POTOSÍ, SLP. MÉXICO



444 127 11 80



444 129 29 79

[info@manufacturaslenin.mx](mailto:info@manufacturaslenin.mx)

[MEXICANTORTILLAMACHINE.COM](http://MEXICANTORTILLAMACHINE.COM)